

Welding information:

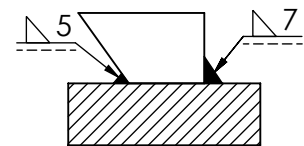

DETAIL A SCALE 1 : 3

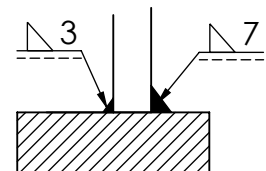

DETAIL B SCALE 1 : 2

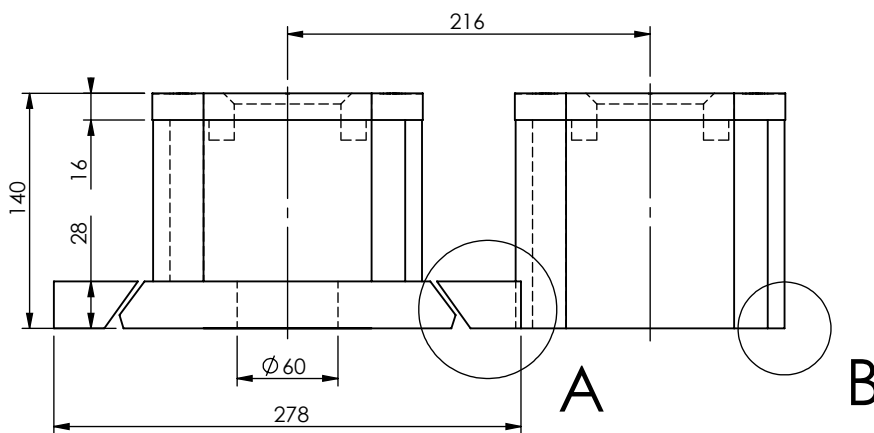

Load type	Shear	Tension
Breaking load (BL)	420 kN	500 kN
Safe working load (SWL)	210 kN	250 kN

Date: 28-06-2021	Revision no.: 001		Scale: 1:4.5
Color/finish: Primed	Weight: 23.7kg		Drawn: K. van Puffelen
Material: Blank Steel	Comment: units in mm		Checked: S. Saeys

## Double Sliding Foundation Longitudinal LC=216mm H=140mm



A4

Drawingno.:

**AC-B2-216-L-140**

© Van Doorn Container Parts BV. All parts contained in this document is protected by the intellectual works of van Doorn container parts BV. Any form of copying, manufacturing or distribution towards third parties is strictly forbidden without the written permission of Van Doorn Container Parts BV. All care has been taken to prevent incorrectness, however Van Doorn Container Parts BV cannot be held responsible for incompleteness resulting from information contained by this document. All rights are reserved by Van Doorn Container Parts BV.