

Top corner casting (B) :

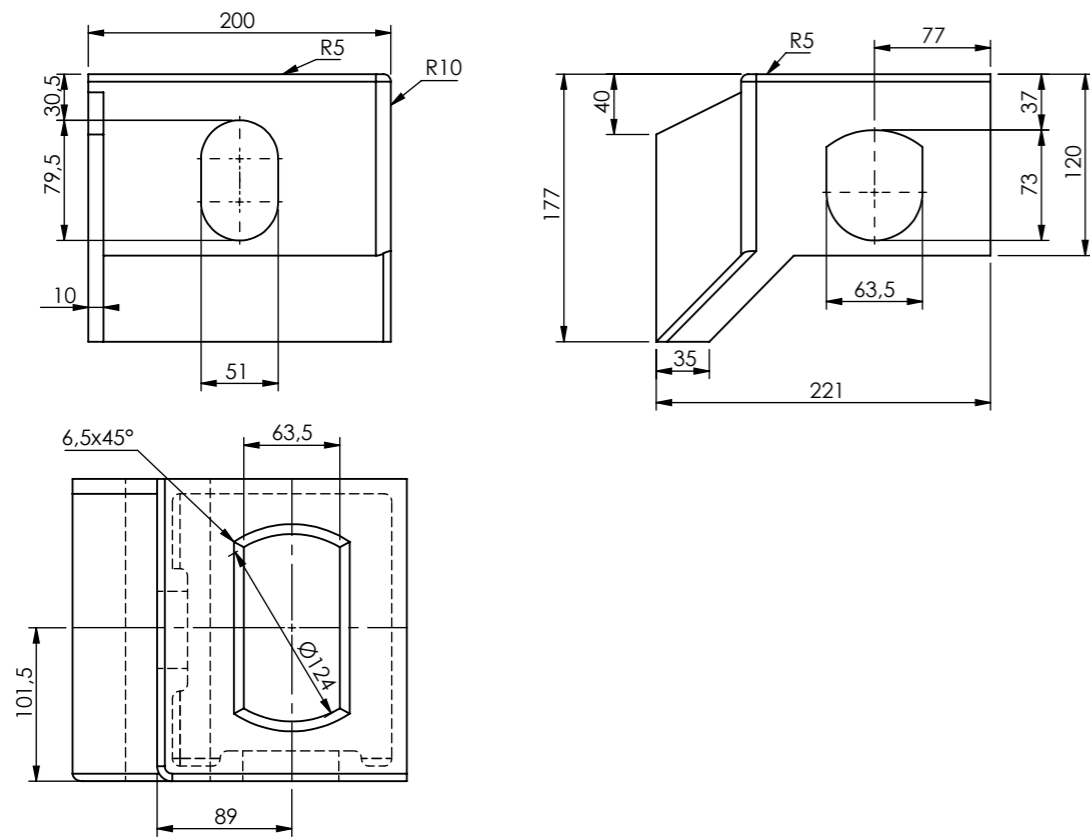

Bottom corner casting (A):

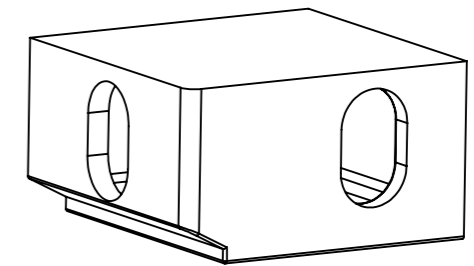
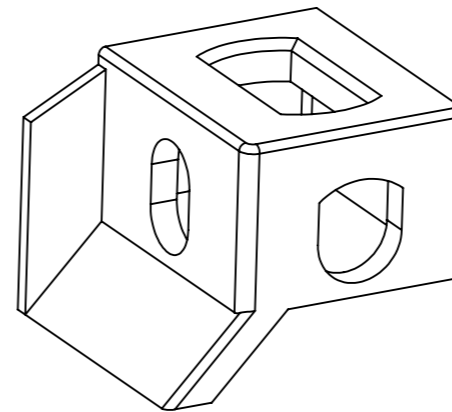
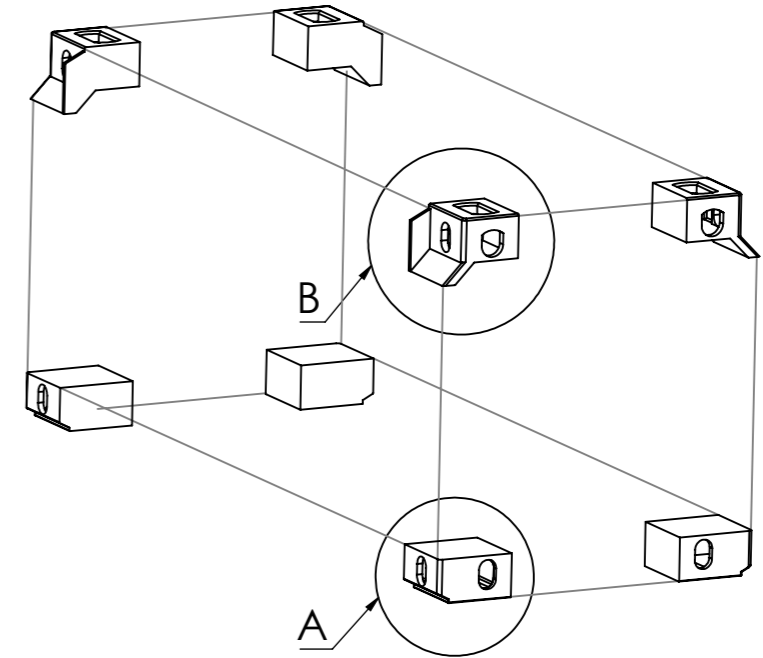
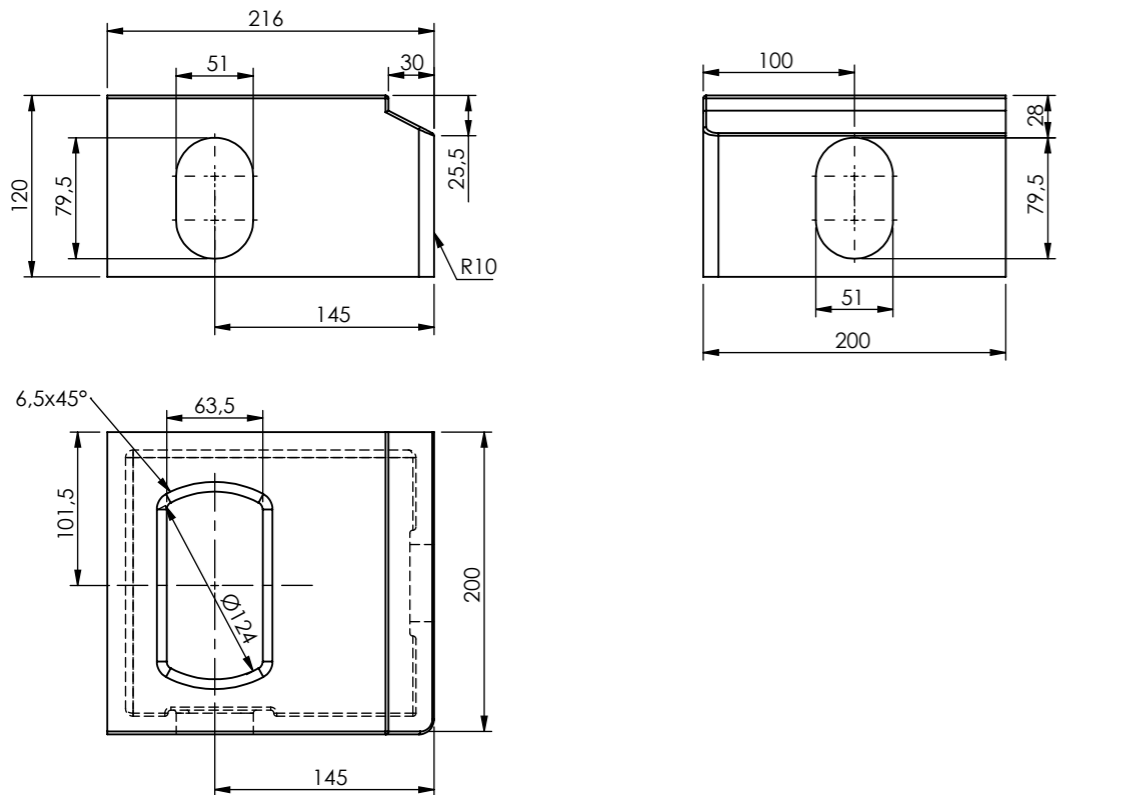

Top corner casting left (B)
(Top right configuration is the mirrored version)

Bottom corner casting (A)
(Bottom right configuration is the mirrored version)

Date: 16-10-2020	Revision no.: 001		Scale: 1:5
Color/finish: Unprimed	Weight: 16.5kg		Drawn: K. van Puffelen
Material: Blank steel	Comment: units in mm		Checked: S. Saey

Cornercasting European Overland 2.55m wide



Drawingno.:
A3
Overland

© Van Doorn Container Parts BV. All parts contained in this document is protected by the intellectual works of van Doorn container parts BV. Any form of copying, manufacturing or distribution towards third parties is strictly forbidden without the written permission of Van Doorn Container Parts BV. All care has been taken to prevent incorrectness, however Van Doorn Container Parts BV cannot be held responsible for incompleteness resulting from information contained by this document. All rights are reserved by Van Doorn Container Parts BV.